



Amstel 7.4kW

**Smart
Socket**

User & Installation Manual



BPE®

BADGER POWER ELECTRONICS

www.BadgerPowerElectronics.com

User Manual Contents	1
1. Safety Information	1
1.1. Important safety instructions.....	1
1.2. Notes.....	2
2. Specification	3
2.1. Datasheet.....	3
2.2. Features.....	4
2.3. Dynamic Load Balancing.....	4
3. Preparation for Installation	5
3.1. Installation requirements.....	5
3.2. Electrical Wiring Diagram.....	6
3.2.1. 230V Single Phase.....	6
3.3. Installation Considerations.....	6
4. In the Box	7
5. Installation Instructions	8
5.1. Step-by-Step Installation Instructions for:.....	8
5.1.1. Bottom Wiring Configuration.....	8
5.1.2. Top Entry Configuration.....	10
5.1.3. Rear Entry Configuration.....	12
5.2. Set the Operating Current	14
5.3. Emergency Shutdown Button.....	14
5.4. Leakage Test.....	15
6. Operating Status	16
6.1. Power ON Checking.....	16
6.2. LED Lights Instruction.....	16
6.3. Buzzer Prompt Description.....	17
7. Maintenance Instructions	18
7.1. Product Servicing.....	18
7.2. Warranty Description.....	18
7.3. Safety Notice.....	18
7.4. Risk Notification.....	19

DLB Box Manual.....20

1. Precautions	21
2. Description	21
2.1. Introduction.....	21
2.2. Performance.....	21
3. Installation Instructions	22
3.1. Accessories.....	22
3.2. DIN Rail Installation.....	22
3.3. Flush Mounted Installation.....	23
3.4. Connection.....	24
4. Safety Instructions & Troubleshooting	25
4.1. Instructions.....	25
4.2. Troubleshooting.....	25

1. Safety Information

1.1. Important Safety Instructions

This document contains important instructions and warnings that must be followed for both installation and maintenance of the EV Charger.



WARNING

- Read this entire document before installing or using the EV Charger.
- Keep children away from operating the EV Charger.
- The EV Charger must be grounded through a permanent wiring system or an equipment grounding conductor.
- Do not install the mounting bracket near flammable, explosive, harsh, or combustible materials, chemicals, or vapours.
- Do not exceed specified EV Charger operating parameters.
- Never spray water or any other liquid directly at the wall mounted EV Charger. Never spray any liquid onto the charge handle or submerge the charge handle in liquid. Store the charger connector above the ground to prevent unnecessary exposure to contamination or moisture.
- Do not use EV Charger if it is defective, appears cracked, frayed, broken, or otherwise damaged, or fails to operate.
- Do not attempt to disassemble, repair, tamper with, or modify the EV Charger yourself. Any maintenance must be performed by authorised technical personnel or our company's technical support. Contact us for any repairs or modification.
- Handle with care when transporting the EV Charger. Do not subject it to strong force, impact or pull, twist, tangle, drag, or step on the EV Charger to prevent it or any components from damage.
- Do not touch the EV Charger's end terminals with sharp metallic objects, such as wire, tools, or needles.
- Do not insert foreign objects into any part of the EV Charger.
- Use of the EV Charger may affect or impair the operation of any medical or implantable electronic devices, such as an implantable cardiac pacemaker or an implantable cardiovascular defibrillator. Check with your electronic device manufacturer concerning the effects that charging may have on such electronic devices before using the EV Charger.



CAUTIONS

- Do not use private power generators as a power source for charging.
- Incorrect installation and testing of the EV Charger could potentially damage either the vehicle's battery and/or the EV Charger itself. Any resulting damage is excluded from New Vehicle Limited Warranty and the EV Charger Limited Warranty.
- Do not operate the EV Charger in temperatures outside its operating range of -25°C to +55°C.

1.2. Notes

- Ensure that the EV Charger's charging cable is positioned so it will not be stepped on, driven over, tripped on, or subjected to damage or stress.
- Do not use cleaning solvents to clean any of the EV Charger's components. The outside of the EV Charger, the charging cable and the connector end of the charging cable should be periodically wiped with a clean dry cloth to remove accumulation of dirt and dust.
- Be careful not to damage the circuit board when removing the power entry knock-out.

2. Specification

2.1 Datasheet

Specification		Amstel 7.4kW Smart
Power Input	Input Rating	230Vac ±10% Single-Phase
	Wiring	L+N+PE
	Frequency	50/60Hz
Power Output	Output Power	7.4kW max
	Output Current	Adjustable from 6A/8A/10A/12A/16A/20A/25A/32A
	Charging Interface	IEC 62196-2 Type 2 tethered or socket only
User Interface & Control	Status Indicators	RGB LED
	Isolator Switch	External Integrated Isolator Switch
	Card Reader	ISO/IEC 14443 A/B Mifare RFID reader
Communication	Network Interface	Wi-Fi/Bluetooth
Operating Features	Operating Modes	Normal, Solar Photovoltaic, Mains Hybrid, Full Speed Mode
	Dynamic Load Balancing	External adjustable DLB function up to 99A
Environmental	Operating Temperature	-25°C to 55°C
	Storage Temperature	-40°C to 70°C
	Humidity	0%-95% no condensation
	Altitude	<3000m
Mechanical	Ingress Protection	IP55
	Cooling	Passive cooling
	Dimension (WxHxD)	140 x 390 x 205mm
	Weight	5kg
	Charging Cable Length	6m (tethered version only)
	Installation	Wall-mounted, Pole-mounted
Regulation	Certifications	CE, UKCA, IEC 61851-21-2018, EN IEC 61851-1:2019
Warranty	Warranty	3 Years

2.2. Features

- Built-in with over-voltage protection, over-current protection, over temperature protection, ground fault detection, CP abnormal signal protection and Type A RCD for Europe standard.
- Operating temperature range: -25°C to 55°C.
- IP55 protecting rate, operating humidity range 0-95% for indoor and outdoor.
- Built-in temperature sensor for fire protection.
- Easy cable storage.
- The EV charger can be wall-mounted or pole-mounted. There are three wiring configurations for the EV charger - bottom, top and rear wiring.
- RFID card or auto-start charging modes.
- International CP mode or compatible modes.
- Rated charging current can be set according to different home load conditions.
- Lightning protection ensures personal safety.
- Standard: EN IEC 61851-1 IEC 61851-21-2.
- Corrosion resistance: Meet GB/T 10125-1997 artificial atmosphere corrosion test and salt spray test.
- Certificate: CE & UKCA.

2.3. Dynamic Load Balancing

Dynamic Load Balancing is integrated within BPE EV Chargers which regulates its power output to harmonise with other household loads to avoid current overloads. This is achieved by reducing the current draw of the EV Charger so the system operates smoothly below the house limit. This optimises home power usage without tripping the breaker.

3. Preparation for Installation

3.1. Installation Requirements

Installation of the EV Charger requires that you:

- Calculate the existing electrical load to determine the maximum operating current.
- Calculate the distance to ensure minimal voltage drop.
- Obtain any necessary permits from the local authority that has jurisdiction and confirm that the follow-up inspection has been scheduled by an electrician after the installation is complete.
- Use only copper conductors.
- Use conductors that are sized in accordance with local wiring regulations. The selected cable must be able to sustain periods of constant load of up to 40A.
- Use protective devices. The circuit protection device chosen must incorporate a suitable residual-current device (RCD) and over-current protection in relation to the electrical load selected.

Choose the Best Location for the EV Charger:

- Determine the parking location of the vehicle to ensure that the charge cable reaches the charge port.
- Determine the parking location of the vehicle to ensure that the current charge cable reaches the charge port in an enclosed garage, typically on the vehicle's charge port side.
- In a well-ventilated area. Avoid installation in an enclosed box, or adjacent to hot appliances.
- 1.2m above the ground.
- 190mm from any obstacle to allow cable collected.

Note:

The EV Charger is approved for outdoor use. Protection from rain is recommended but not required.

3.2. Electrical Wiring

3.2.1. 230V Single-Phase

The L, N and PE should be wired according to local requirements. The phase used must measure 230V ($\pm 10\%$).



- **WARNING:** Each ground must be connected to neutral at only one point, or the EV charger cannot operate.



- **WARNING:** Before installing the EV charger, identify the type of utility service connection available on site. If you are unsure about the type of connection available at the service panel, consult an electrician for assistance.

3.3. Installation Considerations

Three configurations are available to install the EV Charger:

The location of the conduit determines which installation method to follow. If the conduit runs along the floor or low to the wall, use the bottom entry configuration. If the conduit comes from inside the wall, use the rear entry configuration. If the available conduit comes from the ceiling, use the top entry installation.

Note: Throughout the manual, “conduit” is used as the standard term for the protective tubing that houses the service wiring. In regions where conduit is not used (Europe for example), a cable comprised of service wiring enclosed in a protective jacket may be substituted for conduit if allowed by local regulations.

Here are some additional guidelines:

- Conduit openings are sized for 32mm conduit.
- Conduit needs to be metal and flame retardant.
- Use an appropriate circuit breaker.
- To keep the housing waterproof, use cable glands.

4. In The Box



1



2

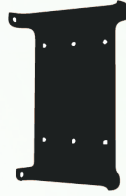

3



4



5



6



7



8



9

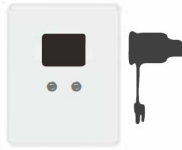

10

NO.	Item	Quantity
1	EV Charger	1
2	Wire Box	1
3	Wirebox Mounting Template	1
4	RFID Card	1
5	M32*1.5 cable gland	1
6	M6*8 Screws	4
7	8*40 Socket head screw and anchoring	6
8	8*40 Flat head screws and anchoring	2
9	Position Template	1
10	DLB box	1

5. Installation Instructions

5.1. Step-by-Step Installation Instructions

5.1.1. Bottom Wiring Configuration

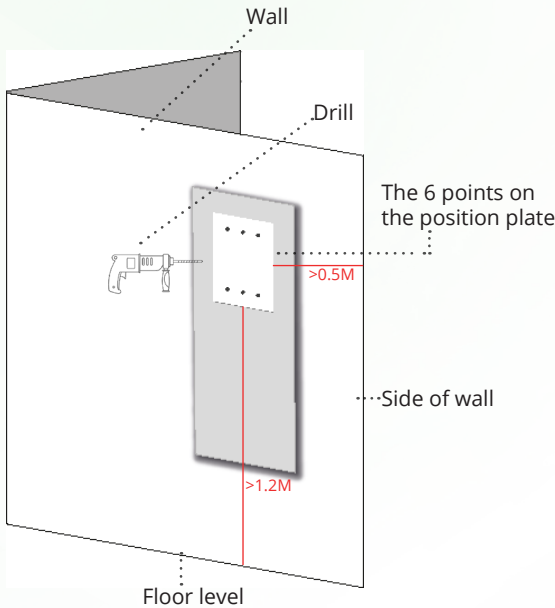

Step 1

Position

Position the mounting template on the wall where the EV Charger will be located.

The picture shows the distances we recommend. At a minimum of 120cm from floor level.

Drilling pilot holes.

Drill the holes according to the instruction on the position template for different installation and wiring configurations.

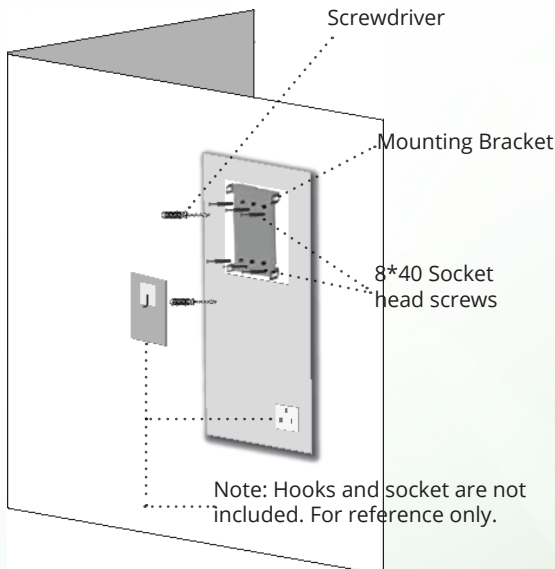

Step 2

Install the Mounting Bracket

Insert the 8*40 Socket head screws into the holes, and use the screw driver to make the 6pcs 8*40 Socket head screws anchor the mounting bracket on the wall.

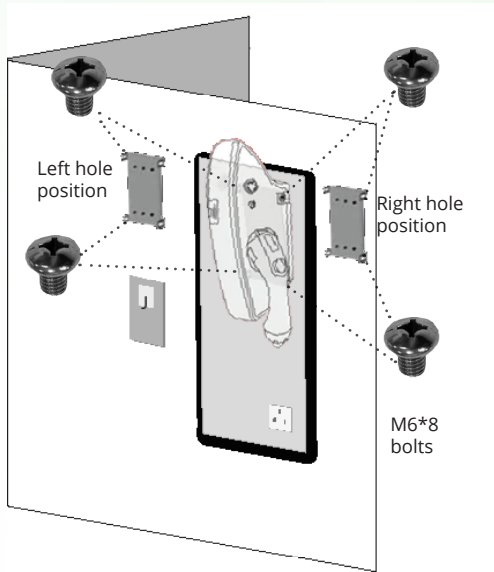

Step 3

Install the EV Charger to the Mounting Bracket

Align the side holes of the EV Charger to the panel's side holes.

Installation

Use the 4pcs M6*8 screws to fix the EV Charger to the mounting bracket as picture shows.

Step 4

Wiring

Note: Consult with your local electrician or refer to your local code for proper wire sizing appropriate for the currents in your EV Charger.

Note: It is the installer's responsibility to identify whether additional grounding is required to ensure that local restrictions are met. Grounding must be installed at the power source and not at the cable entry to the EV Charger.

As the picture on the left shows, use the screwdriver to loosen the screws on the EV Charger cover. Wire the cable to the appropriate terminal.

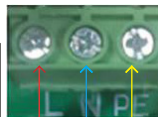
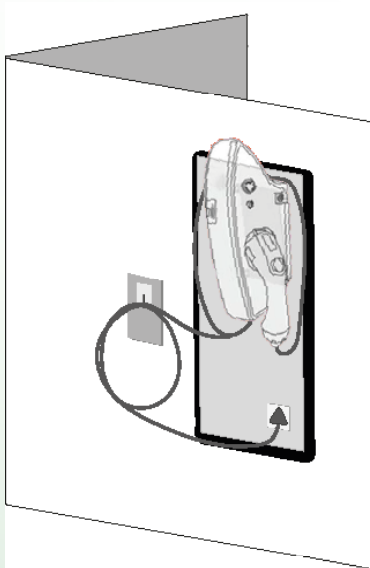

L N PE
Wiring diagram



Wiring terminals

5.1.2. Top Wiring Configuration

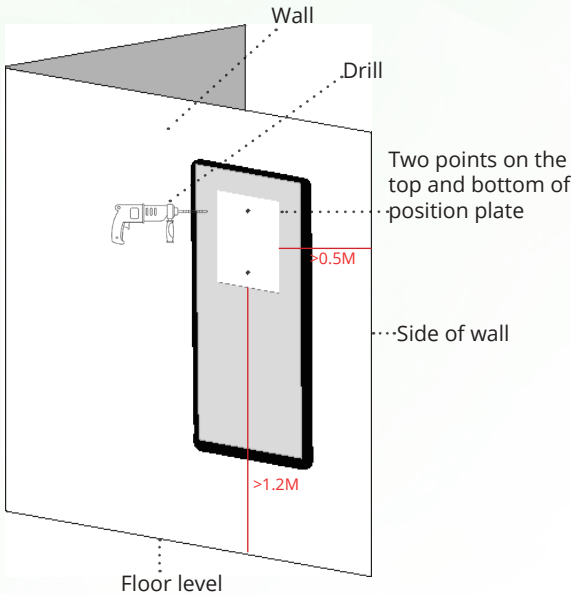

Step 1

Position

Position the template on the wall where you wish to install the EV Charger.

The picture shows the distances we recommend.

At a minimum of 120cm from floor level.

Drilling pilot holes.

Drill two holes according to the instruction on the position template.

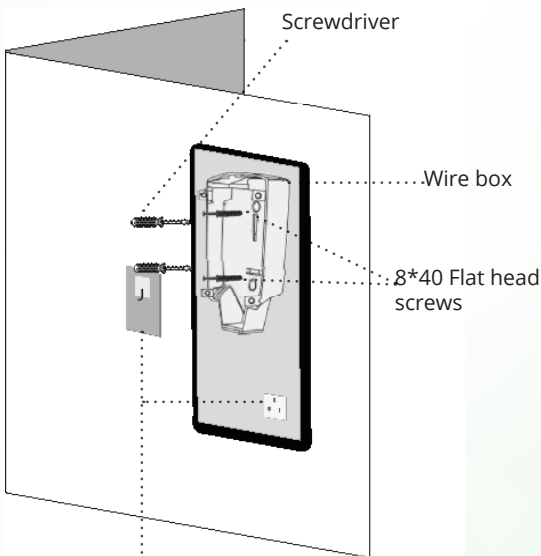

Step 2

Insert the 8*40 Flat head screws into the holes, and use the screw driver to make the 2pcs 8*40 flat head screws anchor the wire box onto the wall.

Note: Hooks and socket are not included. For reference only.

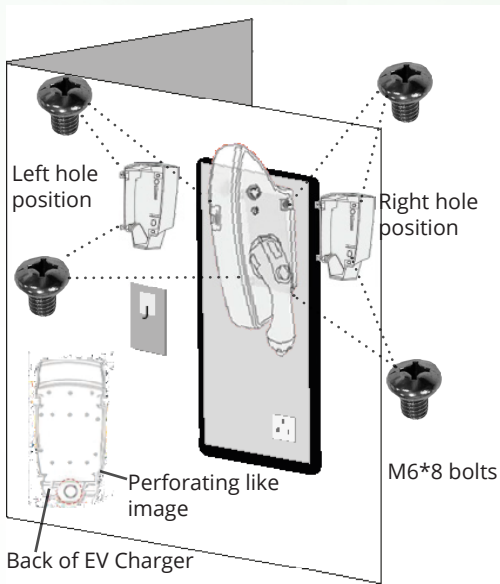

Step 3

Knock out on the back of the EV Charger

Find the hole for the knock out located on the back on EV Charger.

Use the 4pcs M6*8 screws to fix the EV Charger to the mounting bracket as the picture shows.

Step 4

Wiring

Note: Consult with your local electrician or refer to your local code for proper wire sizing appropriate for the currents in your EV Charger.

Note: It is the installer's responsibility to identify whether additional grounding is required to ensure that local restrictions are met. Grounding must be installed at the power source and not at the cable entry to the EV Charger.

As the picture on the left shows, use the screwdriver to loosen the screws on the EV Charger cover. Wire the cable to the appropriate terminal.

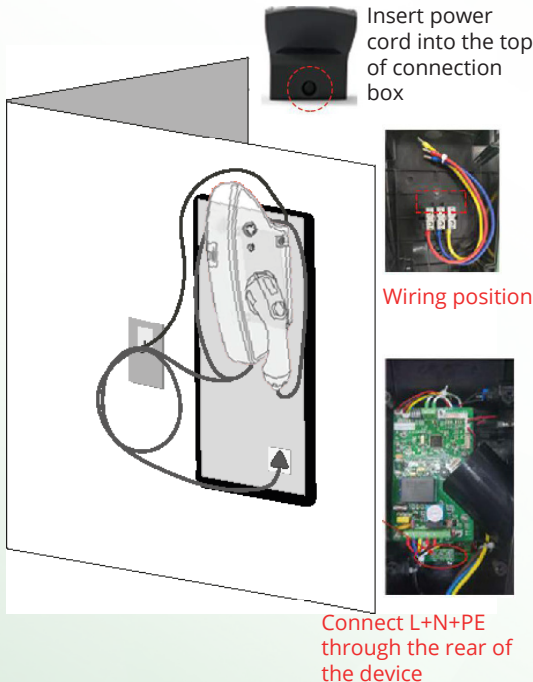

5.1.3. Rear Wiring Configuration

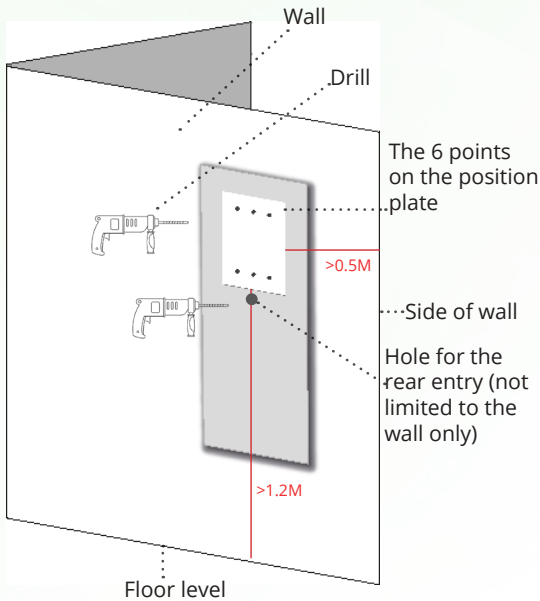

Step 1

Position

Position the mounting template on the wall where the EV Charger will be located.

The picture shows the distances we recommend.

At a minimum of 120cm from floor level.

Drilling pilot holes

Drill the holes according to the instruction on the position template for different installation and wiring configurations.

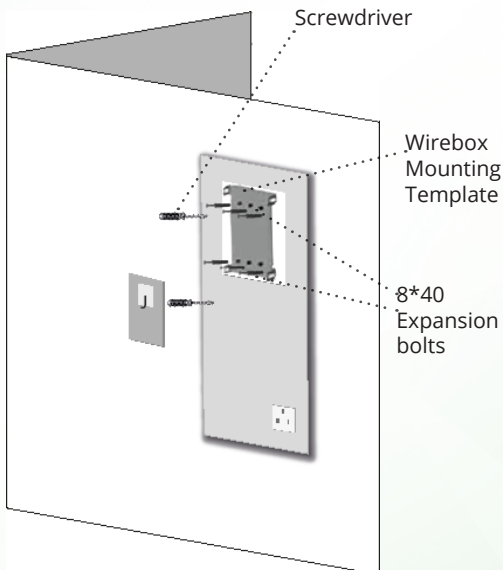

Step 2

Install the Mounting Bracket

Insert the 8*40 Socket head screws into the holes, and use the screw driver to make the 6pcs 8*40 screws anchor the wirebox mounting bracket on to the wall.

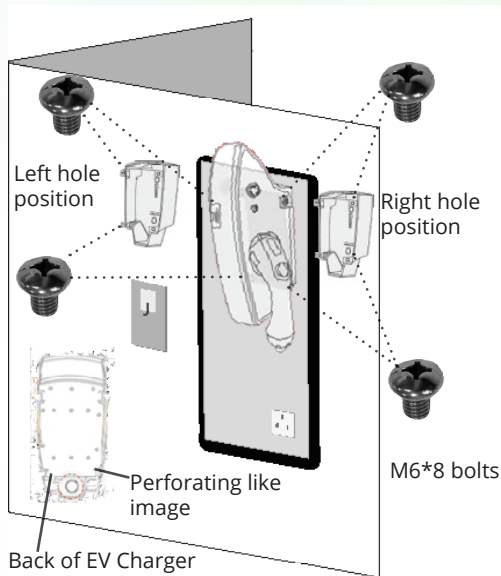

Step 3

Secure the EV Charger to the Mounting Bracket

Find the hole for the knock out located on the back on EV Charger.

Use the 4pcs M6*8 screws to fix the EV Charger to the mounting bracket as the picture shows.

Step 4

Wiring

Note: Consult with your local electrician or refer to your local code for proper wire sizing appropriate for the currents in your EV Charger.

Note: It is the installer's responsibility to identify whether additional grounding is required to ensure that local restrictions are met. Grounding must be installed at the power source and not at the cable entry to the EV Charger.

As the picture on the left shows, use the screwdriver to loosen the screws on the EV Charger cover. Wire the cable to the appropriate terminal.

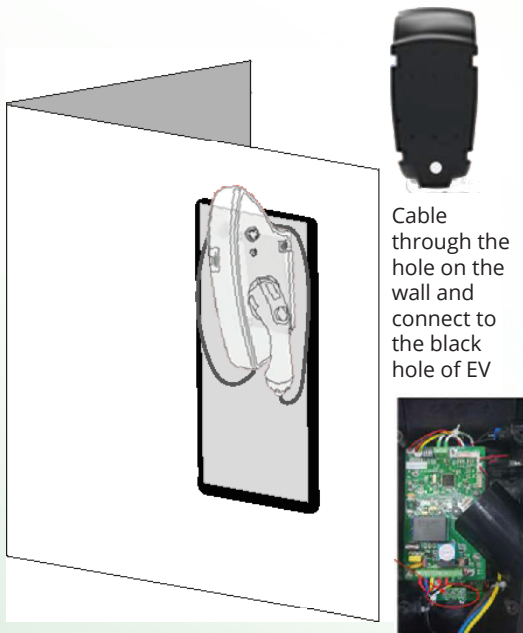

Wiring terminals



WARNING: Be careful of electric shock! Before use, use a voltmeter to confirm that there is no voltage on the power supply line or terminal to ensure that the power has been cut off.

5.2. Reinstall the sealing cover and Turn Power ON

- Use a screwdriver to tighten the screws on the sealing cover. Ensure to tighten screws to these specification: 1.5N·M~1.8N·M torque.
- Recommend to install a circuit breaker: 40A/2P 30mA.



5.3. Emergency Shutdown Button

- Located on the side of the Amstel 7.4kW is a larger red emergency shutdown button.
- In the event of an emergency or another dangerous scenario, you must press down on the emergency shutdown button. This will immediately cease all power flowing through the EV Charger.
- Do not use this feature to end a charging session.
- To reset the Emergency Shutdown Button, you must rotate it clockwise until the button springs back up to the ready position.

5.4. Leakage Test

- Located just below the Emergency Shutdown Button is a small red button which is designed to perform a Leakage Test to ensure that there are no faults within the EV Charger.
- When pressing this button, the MCU will control the circuit to send out a small 10mA analog DC leakage to the Type A RCD to ensure it is functioning properly.
- This action should be carried out each time you are about to start a charging session.

6. Operating Status

6.1. Power ON Checking

NO.	Check Content
1	Check and ensure the circuit breaker for the EV Charger is correctly selected.
2	Confirm that there is no short circuit between the AC output L/N/PE of the charging.
3	Confirm that the EV Charger is not connected to the vehicle.
4	Ensure the circuit breaker is closed.
5	The charger is powered on, and the power-on-self-check is completed in about 10 seconds.
6	After the power-on-self-check is completed, observe the status of the LED indicator. Normal standby: Green flashing light ON. Equipment failure: Yellow light always ON.

6.2. LED Light Instructions

EV Charger	LED Light
No Power	Lights OFF
Power ON Checking	Green, Yellow, Red Lights Flashing
Standby	Green light ON
Plug the connector but do not activate with RFID card (the vehicle is not ready for charging)	Streaming lights from up and down in a circle.
Plug the connector but do not activate with RFID card (the vehicle is ready for charging)	Fast streaming lights going up and down.
Plug the connector but do not activate the RFID card (the vehicle is not ready for charging)	Streaming lights from up and down to middle
Charging	Streaming lights from the middle to up and down
Emergency Stop Protection	Yellow light ON
CP Signal abnormal	Yellow and red LED flicker alternatively (1 second intervals)

Poor grounding/Reversed wire connection	Red Light ON
Over-voltage Protection	Red light flashes (flashing once every 500MS intervals, and then repeats after waiting for 2 seconds)
Under-voltage Protection	Red light flashes (2 flashes at 500MS intervals, and then repeats after waiting for 2 seconds)
Over-current Protection	Red light flashes (interval 500MS)
Temperature	Red light flashes (interval 200MS)
Leakage Protection	Red light flashes (interval 500MS flashes 3 times, wait 2 seconds and repeat)
LED board is offline	The yellow light is on once and then flashes 2 times intermittently (after the yellow light is on for 1 second, it flashes 2 times and 2 seconds at an interval of 250MS)
Plug and auto-start	Yellow light flashes quickly (250MS on, 250MS off)
DLB Offline	The yellow light is on once and the red light is flashing once intermittently (after the yellow light is on for 1 second, the red light flashes once at 250MS intervals and repeats for 2 seconds)
Current abnormal	The yellow light is on once and the red light is flashing 2 times intermittently (after yellow light is on for 1 second, the red light flashes 2 times and 2 seconds at an interval of 250MS)

6.3. Buzzer Prompt Description

Buzzer	Status	Operating
One Short Vibration	RFID operating	Start charging
Two Short Vibrations	RFID operating	Stop charging
One Long Vibrations	RFID operating	NONE

7. Maintenance Instructions

In order to ensure the normal service life of the EV Charger and reduce the risk during use, it must be serviced within the specified time period; the service of the equipment should be carried out by professionals, and qualified and correct tools should be used.

7.1. Product Servicing

- Regularly check whether the product is damaged.
- Ensure that the emergency stop, circuit breaker and other components of the product can be used under any circumstances, and conduct regular tests.
- If a ground fault occurs, first make sure that the grounding cable carries voltage, and then check that there is no high voltage in the system, and then repair the EV Charger.

7.2. Warranty Description

- BPE Amstel 7.4kW EV Charger has a 3 year warranty.
- Ensure that the EV Charger has undergone strict quality commissioning. During the warranty period, if the quality problems occur under normal use, the company will provide a replacement.
- The user's improper handling, installation, incorrect use and maintenance, negligence or natural damage to the product and failure of normal use are not covered by the warranty.

7.3. Safety Notice

Operation and maintenance risk notification

- Do not disassemble or modify charging facilities and wiring without authorisation, otherwise it may cause fire and electric shock accidents.
- In the event of a power failure, there may be a risk of electric shock; charging equipment maintenance is not allowed when the power is not disconnected, and there is a risk of electric shock.

- Do not disassemble or modify charging facilities and wiring without authorisation, otherwise it may cause fire and electric shock accidents.
- In the event of a power failure, there may be a risk of electric shock; charging equipment maintenance is not allowed when the power is not disconnected, and there is a risk of electric shock.

7.4. Risk Notification

- Please confirm whether the parameters of the electric vehicle and the charging equipment match before use, otherwise it may cause damage to the vehicle.
- It is strictly forbidden to use the EV Charger in the case of equipment failure. Do not operate without authorisation when the charging is abnormal. If you find any abnormalities, please shutdown the system.
- Please strictly follow the operating procedures and prompts on the charging equipment, otherwise there is a risk of electric shock and fire.
- In the event of fire, flooding of charging facilities, etc., it is strictly forbidden to approach the charging equipment. Please inform personnel familiar with the equipment and emergency treatment methods for emergency treatment in time.
- Guardians should take good care of children when they are moving around charging facilities to avoid accidents such as electric shock.

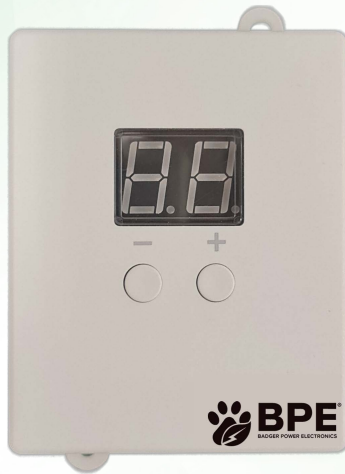

DLB Box Manual

1. Precautions

1. The DLB box should be installed indoors and in a dry environment, ideally within close proximity of the home's main panel.
2. This unit should only be installed by a qualified professional.

2. Description

2.1. Introduction

The DLB (Dynamic Load Balancing) allows the EV Charger to balance its power output to levelise power consumption across all loads within the household.

The DLB box includes a 7 segment display allowing it to visualise the DLB current. The buttons below are used to set the current threshold. (See picture below)

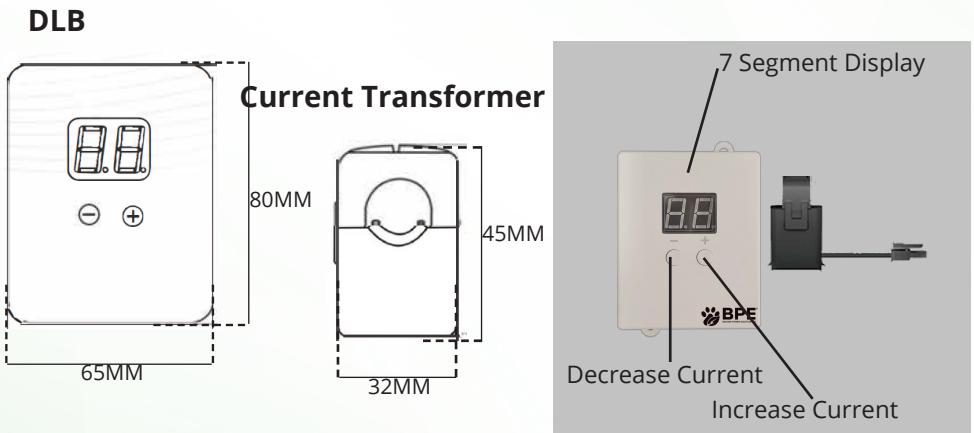

2.2. Performance

Set the Max current value on the DLB box to match the main circuit breaker. The charger will read this current value and automatically adjust the charging current (6A-32A) according to the idle load quota, so that the total household current will not be overloaded due to charging. This function can effectively use the power supply without the need to add/upgrade MCBs.

3. Installation Instructions

3.1. Accessories

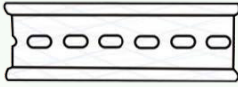

DIN rail 105mm



Current Transformer



M4*30 expansion screw

3.2. DIN Rail Installation

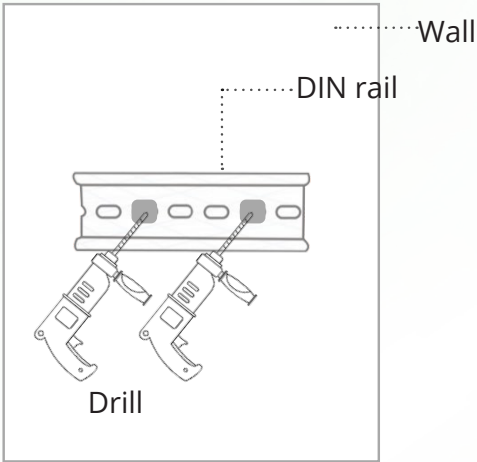

Step 1

Place the rail horizontally on the wall to trace the holes. Use an electric drill to drill the holes.

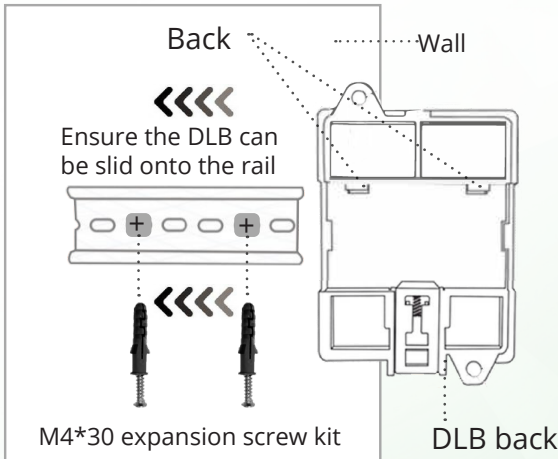

Step 2

Fix the DIN rail with M4*30 expansion screws and then clamp the groove on the back of the DLB box to the DIN rail.

3.3. Flush Mounted Installation

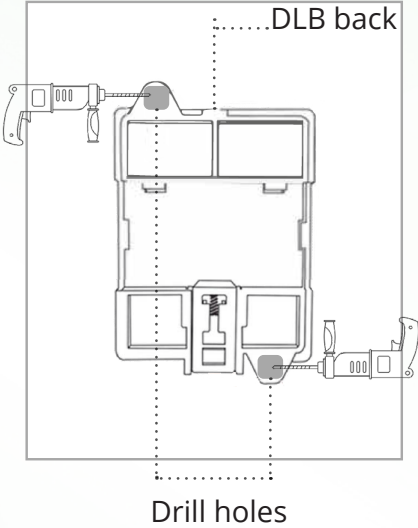

Step 1

Place the DLB box horizontally on the wall to trace holes. Use an electric drill to drill holes.

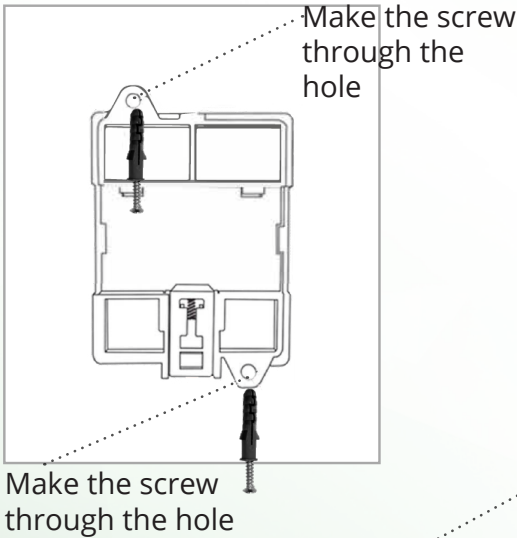

Step 2

Secure the DLB box with provided screws to the wall.

Box will be secured to the wall.



3.4. Connection

Connect the CT wires to the DLB box, located on top of the unit. Ensure the CT clamp is appropriately located on the correct incoming main line. Minimise the length of the wire running from the CT clamp to the DLB box; alternatively use a longer Ethernet cable to connect the DLB box to the EV Charger.

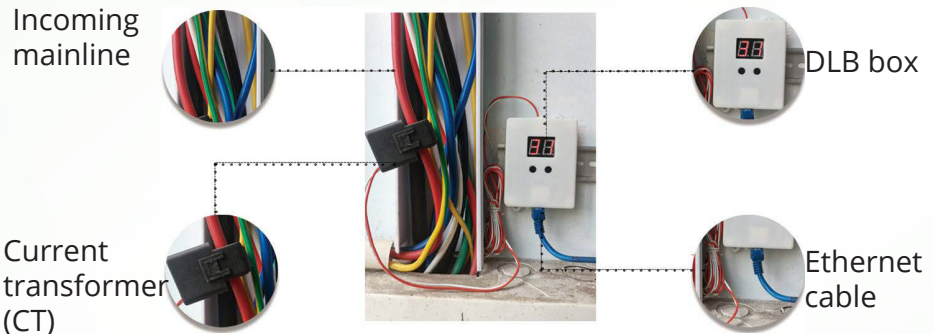

3.5. Network Connection:



1. Connect the Ethernet cable to the bottom of the DLB box.



2. The other end of the Ethernet cable is run to the EV Charger.



3. Connect the Ethernet cable to the comms port.

Please ensure the Ethernet cable is connected securely to the EV Charger and DLB box.

4. Instructions & Troubleshooting

4.1. Setup Instructions

Adjust the buttons on the DLB box to set the DLB current value to match the homes MCB value. Follow the steps shown in the figure below:



Guide:

The 7 segment display (1) shows the total current draw of the house (99A is the max value for this box).

During the setup, you must input the home’s MCB value to ensure the DLB works effectively.

Hold the minus button (2) to decrease the DLB threshold amperage.

Hold the positive button (1) to increase the DLB threshold amperage.

Wait 3-5 seconds to allow the DLB box to save your preferred settings.

4.2. Troubleshooting

1. Fault type

- DLB offline: The LED lights on the EV Charger will flash yellow then red sequentially.
- DLB abnormal current: The LED lights on the EV Charger will flash yellow followed by two red flashes.

2. Possible Faults / Issues

- RS485 communication module is damaged.
- Loose connection.....
- The CT clamp is not fully closed.....



3. Solution

- Replace RS485 communication module
- Check the connection line, ensure the connection is properly seated in its housing.
- Close the CT clamp properly and wait to hear the click.



BPE[®]

BADGER **POWER** ELECTRONICS
www.BadgerPowerElectronics.com