



BPE®

BADGER POWER ELECTRONICS

www.BadgerPowerElectronics.com



**BPE-MI-500, BPE-MI-800,
BPE-MI-2000**

Photovoltaic Grid-Connected Microinverter

Installation / User Manual

Contents

1. Information and Safety Instructions	1
1.1. Safety Instructions.....	1
1.2. Communication Statement.....	2
1.3. Symbol Definitions.....	2
1.4. System Components.....	3
2. Microinverter System Introduction	4
2.1. Microinverters maximize PV energy production.....	4
2.2. More reliable than centralised or string inverters.....	4
2.3. Simple to install.....	4
2.4. Smart system performance monitoring and analysis.....	4
3. Microinverter System Installation	5
3.1. Additional Installation components.....	5
3.2. Required Parts and Tools.....	5
3.3. Installation Procedures.....	6
3.4. Microinverter system operating instructions.....	9
3.5. Troubleshooting.....	9
3.6. Troubleshooting an Inoperative Microinverter.....	10
3.7. Maintenance.....	11
4. Replacing a Microinverter	12
5. Technical Data	13
6. Datasheets	14
7. Wiring Diagrams	16

1. General Information and Safety Instructions

1.1. Safety Instructions

This manual contains important instructions for the correct installation and maintenance of the Photovoltaic Grid-connected Inverter (Microinverter). To reduce the risk of electric shock and ensure safe installation and operation of the Microinverter, the following symbols appear throughout this document to indicate dangerous conditions and important safety considerations.

Specifications are subject to change without notice – please ensure you are using the most recent version found at the manufacturer’s website.

WARNING SYMBOL: Indicates a situation where failure to follow instructions appropriately may cause a serious hardware failure or personal injury. Use extreme caution when performing this task.



NOTE SYMBOL: Displays information that is important for optimized microinverter operation. Follow these instructions closely.



- **DO NOT** disconnect the PV module from the Microinverter without first disconnecting the AC power.
- Only qualified professionals should install and/or replace the Microinverters.
- Perform all electrical installations in accordance with local electrical codes.
- Before installing or using the Microinverter, please read all instructions and cautionary markings in the technical documents and on the Microinverter system and the solar-array.
- Be aware that the body of the Microinverter is a heat-sink, and can reach temperatures close to 80° C. To reduce risk of burns, do not touch the body of the Microinverter.
- **DO NOT** attempt to repair the Microinverter. If it fails, contact Customer Support to obtain an RMA number and start the replacement process. Damaging or opening the Microinverter will void the warranty.
- Caution! The external protective grounding conductor is connected to the inverters grounding terminal through the AC connector.
For connection: Connect the AC connector first to ensure inverter grounding, then perform the DC connections.
When disconnecting: First disconnect the AC connector by opening the branch circuit breaker, with the protective grounding conductor still connected. Disconnect the DC inputs afterwards.
- Under no circumstances should you connect DC input when the AC connector is unplugged.
- Please install isolation switching devices on the AC side of the inverter.

1.2. Communication Statement

The entire BPE Microinverter range is equipped with built-in Wi-Fi communication, this allows installations to be connected directly to our online monitoring software without the need for additional hardware.

Wi-Fi integration allows for smoother installations and faster commissioning; thus saving time and money when installing BPE Microinverters.

1.3. Symbol Definitions



Trademark.



Caution, risk of electric shock.

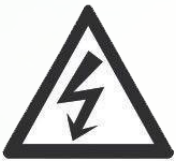

Caution, hot surface.



Symbol indicating electrical and electronics device disposal according to Directive 2002/96/EC. Indicates that the device, accessories and the packaging must not be disposed of as unsorted municipal waste. Waste electrical equipment should be collected and disposed of separately. Please follow your local ordinances/regulations for disposal or contact an authorized representative of the manufacturer for information concerning the decommissioning of equipment.



The CE mark is attached to the solar inverter to verify that the unit follows the provisions of the European Low Voltage and EMC Directives.



Refer to the operating instructions.

Person requires supervision by an adequately trained person in order to avoid the risks and hazards associated with electricity. For the purposes of the safety information contained in this manual, "an adequately trained person" is someone who is familiar with requirements for safety, refrigeration system and EMC, and is authorised to energise, tag equipment, systems, and circuits in accordance with established safety procedures. The inverter and end user system may only be commissioned and operated by qualified personnel.

1.4. System Components

The microinverter is used in utility-interactive grid-tied applications, comprising of three key elements:

- Microinverter
- Wi-Fi router
- Web-based monitoring system

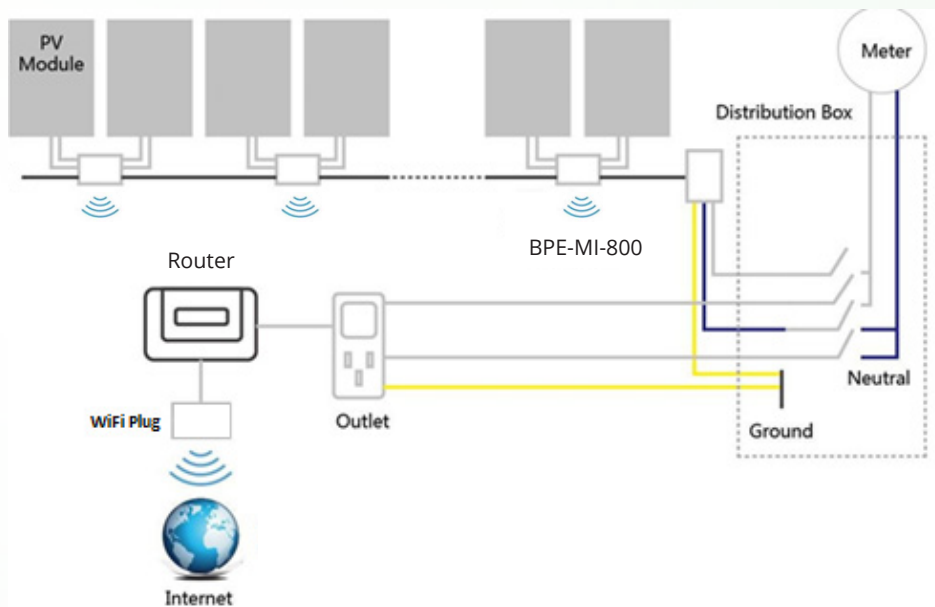

2. Microinverter System Introduction

This integrated system improves safety, maximizes solar energy harvest and increases system reliability. It also simplifies solar system design, installation, maintenance and management.

2.1. Microinverters maximize PV energy production

Each PV module has individual Maximum Peak Power Tracking (MPPT) controls which ensures that the maximum power is transmitted to the utility grid regardless of the performance of the other PV modules in the array. When PV modules in the array are affected by shade, dust, orientation, or any situation in which one module under-performs compared with the other units, the microinverter ensures peak performance from the array by maximizing the performance of each module.

2.2. More reliable than centralised or string inverters

The distributed microinverter system ensures that no single point of failure exists across the PV system. Microinverters are designed to operate at maximum power within ambient outdoor temperatures, including up to 149 °F (65 °C). The inverter housing is designed for outdoor installation and complies with the IP67 environmental enclosure rating.

2.3. Simple to install

Individual PV modules can be installed in any combination of Module quantity, orientation, different type and power rate. The ground wire (PE) of the AC cable is connected to the chassis inside the microinverter. This may potentially eliminate the installation of a grounding wire (check this with local regulations).

2.4. Smart system performance monitoring and analysis

Wi-Fi connectivity enables access to user-friendly online monitoring software that provides real-time system performance data right down to the

The Microinverters connect with the single-phase grid. A three-phase grid can also be achieved through the use of multiple microinverters which operates with most 60 and 72 cell PV modules. For more information, please see the Technical Data page (p.18) of this manual.

Model	Grid Parameters	Max. PV Module Size	Max. # per Branch	Module Connector
BPE-MI-500	230VAC @ 50Hz	700W x 1	8	MC4
BPE-MI-800	230VAC @ 50Hz	700W x 2	6	MC4
BPE-MI-2000	230VAC @ 50Hz	750W x 4	4	MC4

3. Microinverter System Installation

Setting up microinverters for a PV system is simple. Each microinverter easily mounts on the PV racking directly beneath the PV module(s). Low voltage DC wires connect from the PV module directly to the microinverter, eliminating the risks associated with high DC voltage. Installation **MUST** comply with local regulations and technical rules.

Special Statement! An AC GFCI device **should not** be used to protect the dedicated circuit to the microinverter even though it is an outside circuit. None of the small GFCI devices (5mA-30 mA) are designed for back feeding and will be damaged. In a similar manner, AC AFCIs have not been evaluated for back feeding and may be damaged if back fed with the output of a PV inverter.

WARNING: Perform all electrical installations in accordance with local electrical codes.



WARNING: Be aware that only qualified professionals should install and/or replace microinverters.



WARNING: Before installing or using a microinverter, please read all instructions and warnings in the technical documents, on the microinverter system itself as well as on the PV array.



WARNING: Be aware that installation of this equipment includes the risk of electric shock.



WARNING: Do not touch any live parts in the system including the PV array while the system is connected to the electrical grid.



NOTE: It is strongly recommended to install surge protection devices in the dedicated meter box.



3.1. Additional installation components

- AC male and female connectors (sold separately)
- Sealing end caps (sold separately)

3.2. Required part and tools

In addition to your PV array and it's associated hardware, the following items are required:

- An AC connection junction box
- Mounting hardware suitable for module racking
- Sockets and wrenches for mounting hardware
- Continuous grounding conductor and washers
- A cross head screwdriver
- A torque wrench

3.3. Installation Procedures

Step 1 - Install the AC branch circuit junction box

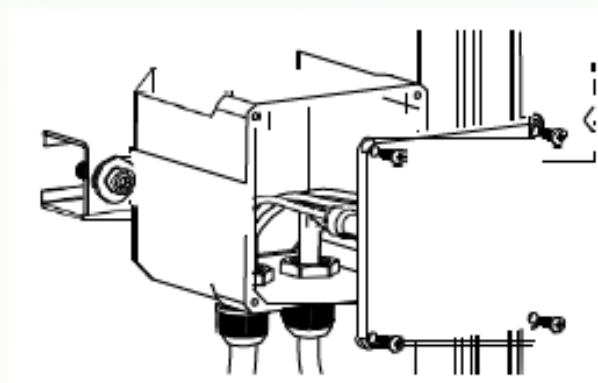
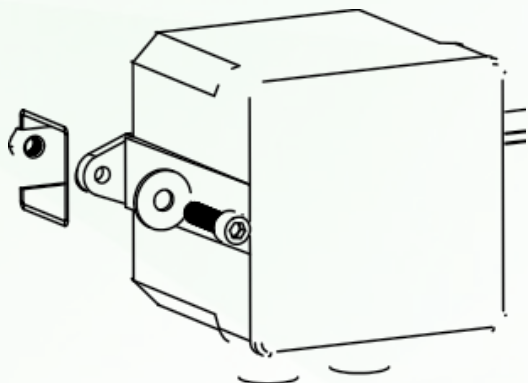

1. Install an appropriate junction box at a suitable location on the PV racking system (typically at the end of a branch of modules).
2. Connect the open wire end of the AC cable into the junction box using an appropriate gland or strain relief fitting.
3. Wire the conductors of the AC: L - RED; N - BLACK; PE - YELLOW GREEN.
4. Connect the AC branch circuit junction box to the point of utility interconnection.

WARNING: The wiring colour code can be different according to local regulation. Check that all of the installed wire colours match regulation before connecting the AC cable. Incorrect cabling can irreparably damage the microinverters. This error is not covered by the warranty.



Step 2 - Attach the microinverters to the racking or the PV module frame

1. Mark the location of the microinverter on the rack, with respect to the PV module junction box or any other obstructions.
2. Mount one microinverter at each of these locations, using the hardware recommended by your module racking vendor.

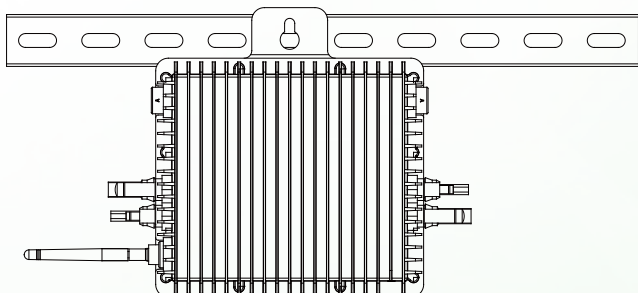

500/800W Mounting

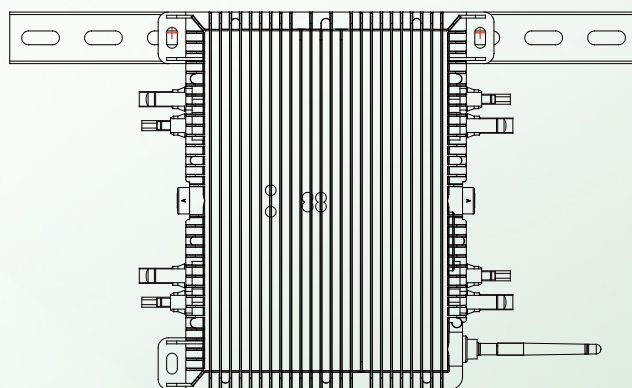

2000W Mounting

WARNING: Prior to installing any of the microinverters, verify that the utility voltage at the point of common connection matches the voltage rating on the microinverter label.



WARNING: Do not place the inverters (including DC and AC connectors) where they can be exposed to the sun, rain or snow. Allow a minimum of 3/4" (1.5 cm) between the roof and the bottom of the microinverter to allow proper air flow.



Step 3 - Connect the microinverters in parallel



500/800W connect in parallel



2000W connect in parallel

- Check the microinverter technical data page (p.18) for the maximum allowable number of microinverters on each AC branch circuit.
- Plug the male AC connector of the microinverter into the female counterpart.

AC connector interface as follows:

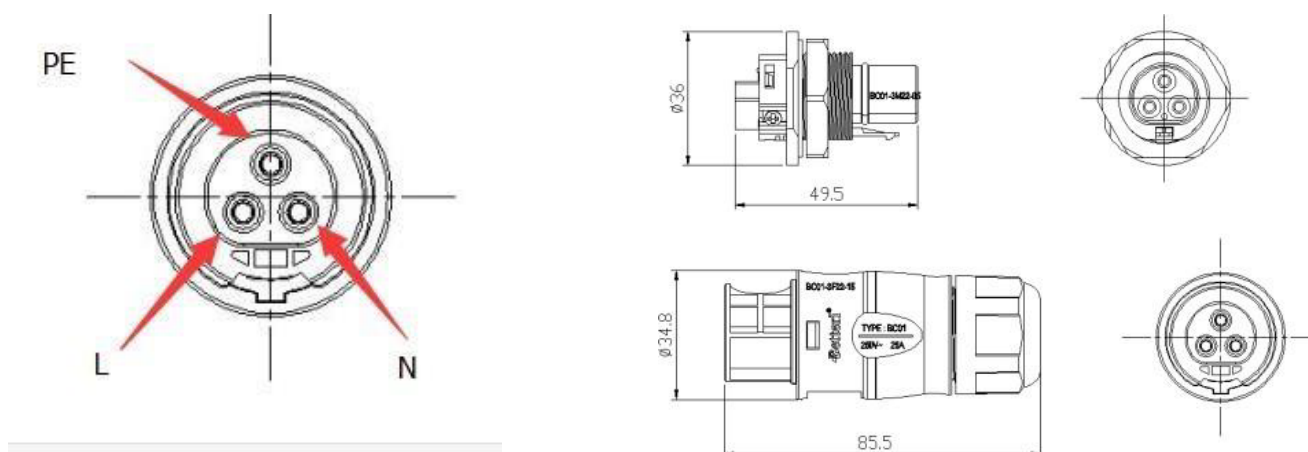

WARNING: Do NOT exceed maximum number of microinverters in an AC branch circuit, as displayed on the page 7 of this manual.



Step 4 - Install an AC cable protective end cap at the end of AC cable

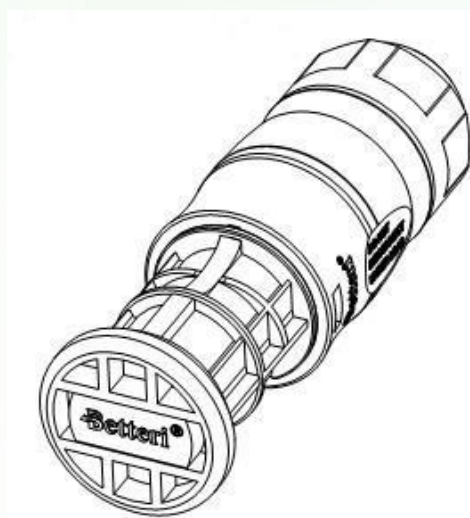
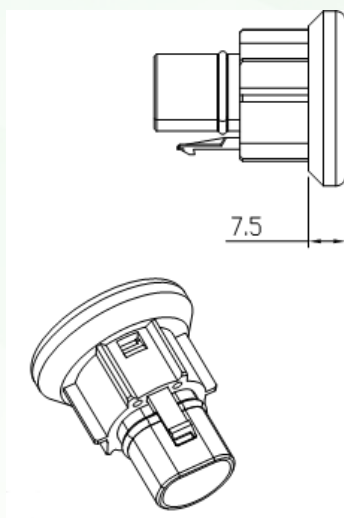

Step 5 - Connect Microinverters to the PV Modules

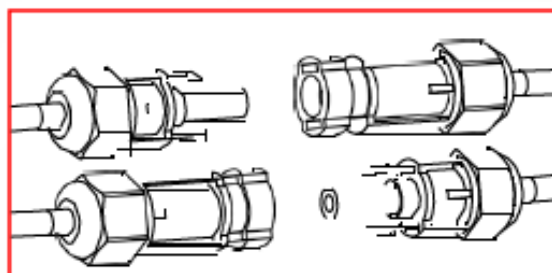
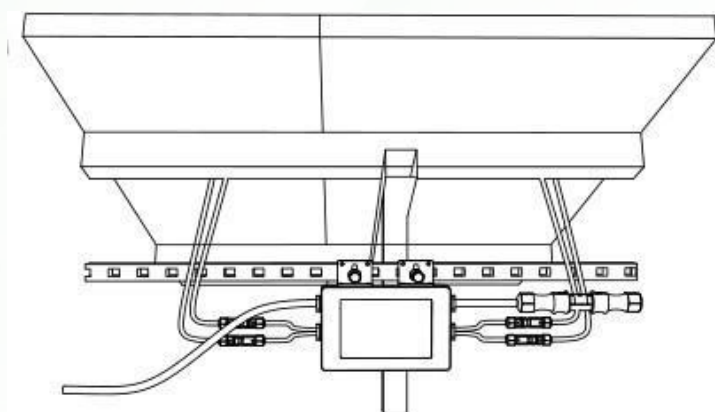

NOTE: When the DC cables are plugged in, the microinverter LED should immediately blink red once, followed by three short green blinks. This will happen as soon as the cables are plugged in, indicating that the microinverter is functioning correctly. This entire function will occur within 5 seconds of plugging in the unit, so pay careful attention to the LED when connecting the DC cables.



WARNING: Double-check to make sure all of the AC and DC wiring has been correctly installed. Ensure that none of the AC and/or DC wires are pinched or damaged. Make sure that all of the junction boxes are properly closed.



3.4. Microinverter system operating instructions

Microinverter PV System Operation:

1. Turn ON the AC circuit breaker on each microinverter AC branch circuit.
2. Turn ON the main utility-grid AC circuit breaker. Your system will start producing power after a one-minute waiting time.
3. The unit LEDs should start blinking red approximately one minute after turning on the AC circuit breaker. The LED should then blink blue. This indicates that the units are functioning normally. The faster the LED blinks blue, the more power is generated.
4. Connect the microinverters to the Wi-Fi if you intend to use the online monitoring software.

NOTE: Once AC power is supplied, about 0.1 A current and 25 VA(W) power for each microinverter may be measured with a meter. The current and power are reactive. The inverters ARE NOT operating. After an over 60s waiting time, the inverters will start operation.



3.5. Troubleshooting

Qualified personnel should use the following troubleshooting steps if the PV system is inoperative:

Status Indications and Error Reporting

Startup LED

One minute after DC power is first applied to the microinverter, one short red blink indicates a successful microinverter startup sequence. If two or more short red blinks occur after DC power is first applied to the microinverter, a failure during microinverter setup has occurred.

Operation LED

- Flashing Slow Blue - a small amount of power is produced.
- Flashing Fast Blue - large amounts of power are produced.
- Flashing Red - Not producing power.
- Red blinking twice - AC low-voltage or high-voltage.
- Red blinking three times - Grid malfunction.

GFDI LED

If the LED blinks four times, it indicates that the Microinverter has detected a Ground Fault Detector Interrupter (GFDI) error in the PV system. Unless the GFDI error has been cleared, the LED will continue to blink 4 times in sequence.

WARNING: Only qualified personnel should directly handle the microinverter.



WARNING: Never disconnect the DC wire connectors under load. Ensure that no current is flowing through the DC wires prior to disconnection. An opaque covering may be used to protect the module prior to disconnecting the module.



WARNING: Always disconnect the AC power before disconnecting the PV module wires from the microinverter. Either disconnect through the appropriate AC circuit breaker or unplug the AC connector to the first microinverter of a branch circuit. Both are suitable as a means of disconnection.



WARNING: The microinverter is powered by the PV module DC power. AFTER disconnecting the DC power, when reconnecting the PV modules to the microinverter, pay attention for the three short LED flashes.



3.6. Troubleshooting an Inoperative Microinverter

There are two malfunction possibilities:

- The microinverter itself may be experiencing problems.
- The microinverter is working, but it having trouble communicating over Wi-Fi. The items below refer to microinverter issues, which exclude communication issues

Quick ways to tell whether the issue is inside the microinverter or a communication problem:

- 1. Diagnosing the Microinverter:** A red LED light – either blinking or solid, or no light at all. No light or a red light indicates a malfunction within the microinverter.
- 2. Diagnosing a poor connection:**
 - **No-Data-Display:** This is probably a communication issue - not a microinverter problem.
 - **Problems with erratic display:** Data is displayed for random periods of time, this is most likely a communication issue.
 - **0 W, or 2 W:** Possibly a microinverter problem

To troubleshoot an inoperative microinverter, follow the instructions below:

1. Verify that the utility AC voltage and frequency are within the ranges indicated in the Technical Data section of this manual.
2. Check the connection to the utility grid. Verify utility power is present at the inverter in question by removing AC, then DC power. Never disconnect the DC wires while the microinverter is transmitting power. Re-connect the DC module connectors and watch for three short LED flashes.
3. Check the AC branch circuit interconnection between all the microinverters. Verify each inverter is energised by the utility grid as described in the previous step.
4. Make sure that the AC breakers are functioning properly and are closed.
5. Check the DC connections between the microinverter and the PV module.
6. Verify that the PV module DC voltage is within the allowable range indicated in the Technical Data of this manual.
7. If the problem persists, please email Customer Support at: techsupport@badgerpowerelectronics.com.

WARNING: Do not attempt to repair the microinverter. If troubleshooting methods fail, please call for Technical Support.



3.7. Maintenance

Maintenance is not required.

4. Replacing a Microinverter

Follow the procedure to replace a failed microinverter:

1. Disconnect the microinverter from the PV module, in the order shown below:
 - i) Disconnect the AC by turning off the branch circuit breaker.
 - ii) Disconnect the AC connector of the microinverter.
 - iii) Cover the module with an opaque casing.
 - iv) Disconnect the PV module DC wire connectors from the microinverter.
 - v) Remove the microinverter from the PV array.
2. Remove the opaque cover, then install a replacement microinverter to the rack. Remember to consider the flashing LED light as soon as the new microinverter is plugged into the DC cables.
3. Connect the AC cable of the replacement microinverter.
4. Close the branch circuit breaker, and verify proper operation of the replacement microinverter.

5. Technical Data

WARNING: Be sure to verify that the voltage and current specifications of your PV module match with those of the Microinverter. Please refer to the datasheet or user manual.



WARNING: You must match the DC operating voltage range of the PV module with the allowable input voltage range of the Microinverter.



WARNING: The maximum open circuit voltage of the PV module must not exceed the specified maximum input voltage of the inverter.



6. Datasheets

BPE Microinverter Datasheets

	BPE-MI-500-EU	BPE-MI-800-EU	BPE-MI-2000-EU
Input Data (DC)			
Recommended Input Power (STC)	300-700W (60-75 cell panels)	600-700W (2 Panels)	450-750W (4 Panels)
Maximum Input DC Voltage (V)	60		
MPPT Voltage Range (V)	24-50		
Full Load DC Voltage Range (V)	16-60		
Max. DC Short Circuit Current (A)	20A	30Ax1 or 20Ax2	20Ax4
Max. Input Current (A)	18A	26Ax1 or 13Ax2	18Ax4
No.of MPP Trackers	1	2	4
No.of Strings per MPP Tracker	1		
Output Data (AC)			
Max. Output Apparent Power (VA)	520	820	2000
Rated Output Power (W)	500	800	2000
Rated Output Current (A)	2.27A	3.64A	9.70A
Max.AC Output Current (A)	2.27A	3.64A	9.70A
Grid Connection Form Rated output voltage/range (V)	L+N+PE 220V/189V-260V 230V/ 189V-260V		
Rated Grid Frequency/range (Hz)	50Hz/46.5Hz-52.5Hz 60Hz/57.5Hz-62Hz		
Power Factor Adjustment Range	>0.99		
Total Harmonics Current Distortion (THDi)	<3%		
DC Component Of Grid	<0.5%In		
Maximum Units per Branch	8	6	4
Efficiency			
Max Efficiency	96.5%		
MPPT Efficiency	>99%		
Mechanical Data			
Night Time Power Consumption	<100mW		
Ambient Temperature Range	-40-70°C, >45°C Derating		
Dimensions (WxHxD mm)	210x230x34mm	218x215x40mm	389x302x43mm
Weight (kg)	2.39	3.6	7.2
Cooling	Natural Cooling		
Enclosure Environmental Rating	IP67		
Features			
Communication	WIFI/PLC		
Grid Connection Standard	VDE-AR-N 4105, IEC/EN61000,IEC/EN62109-1/2,EN50549-1/2019,TOR 2019, C10/11:2019,CEI 0-21 UTE C15-712-1:2013,VFR 2019		
Safety EMC / Standard	IEC/EN 61000-6-1/2/3/4, IEC/EN 62109-1, IEC/EN 62109-2		
Warranty	10 Years (25 Years Optional)		

Sample Wiring Diagram Single Phase for Europe

BPE-MI-800-EU (2MPPT)

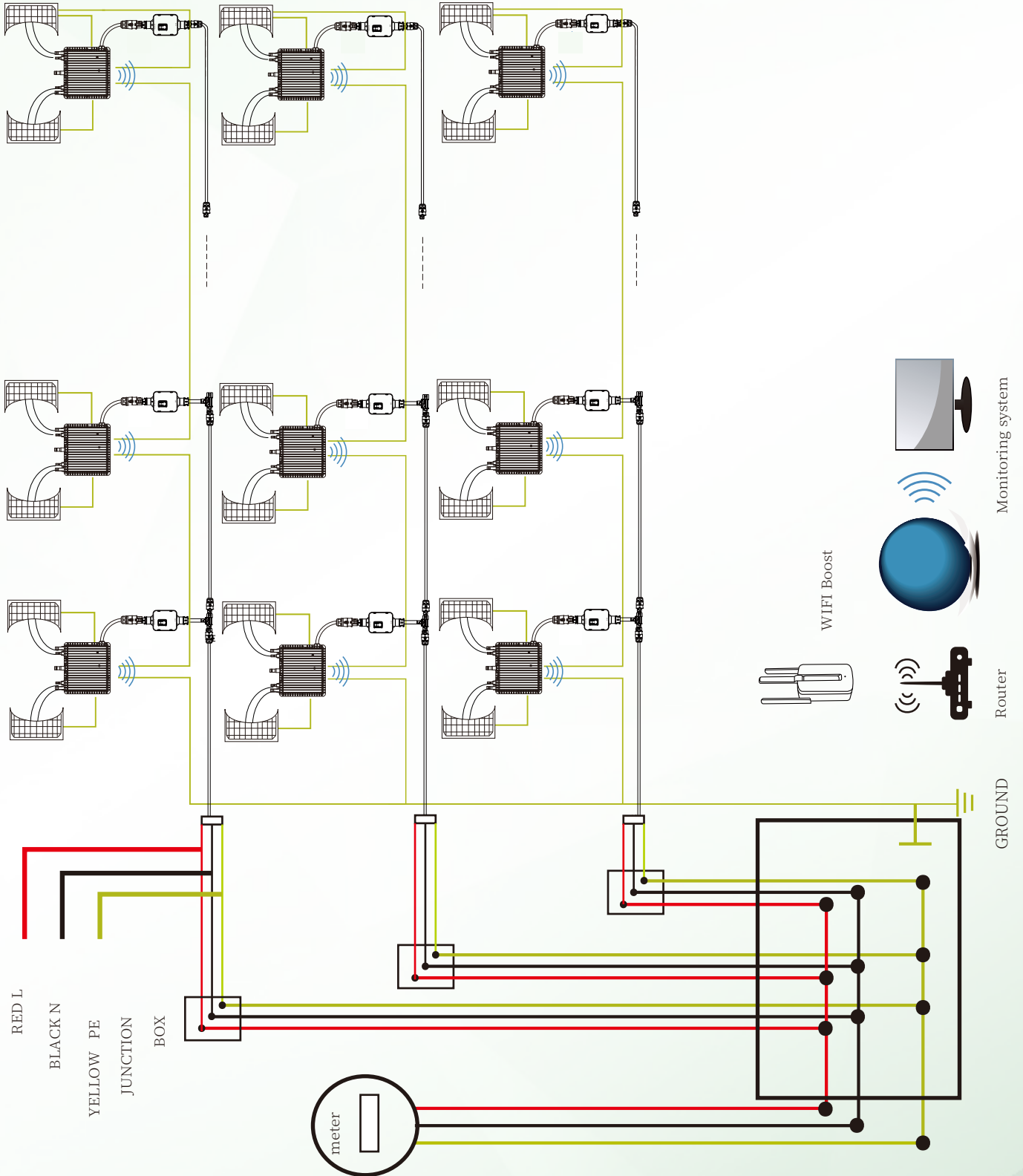

7. Wiring Diagram

Sample Wiring Diagram Three Phase for Europe

BPE-MI-800-EU (2MPPT)

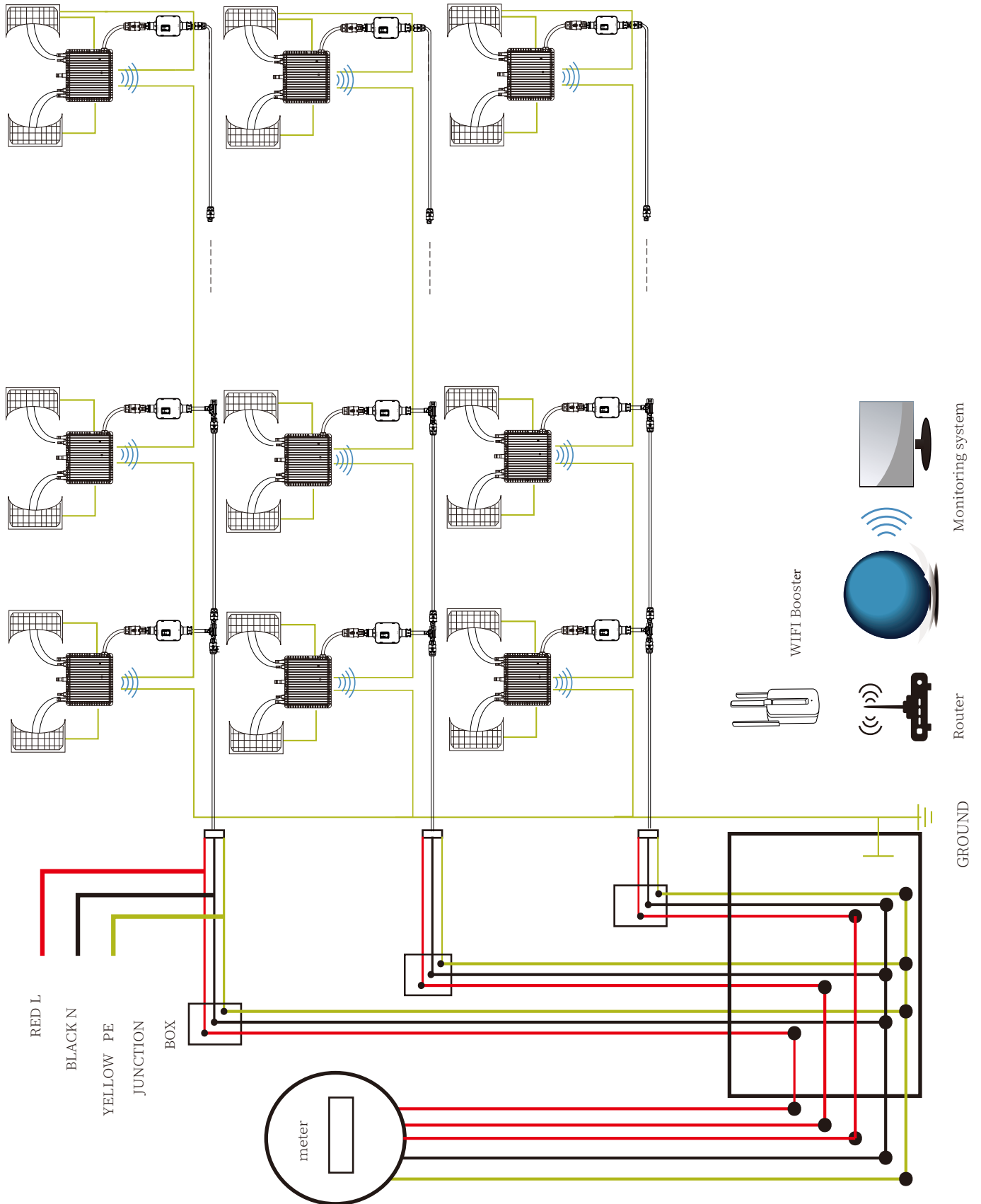



BPE®

BADGER POWER ELECTRONICS

www.BadgerPowerElectronics.com